

# FlexCUBE™ Modular Battery Racks – Installation Instructions

## Product Description

The PowerUpESS 4U Modular Battery Racks are designed to provide a flexible and safe way to store 4U (7") x 17" Lithium-Ion batteries. These racks are manufactured in the USA and are of the highest quality steel and scratch resistant powder coated black matt finish.

## Product Numbers

BR2T4U17	2 battery rack, powder coated, 4U x 17" wide.
BR3T4U17	3 battery rack, powder coated, 4Ux17" wide.
BR4T4U17	4 battery rack, powder coated, 4Ux17" wide.

## Warning/Caution Notations

CAUTION	All work should be completed by qualified personnel.
WARNING	Batteries modules are heavy and should be lifted by two people.
WARNING	No more than two racks should be stacked.

## Required Tools

- Phillips #2 screwdrivers
- 13mm wrench
- 3/8" torque wrench with 13mm socket
- Personal protective equipment

## Expected Installation Time

One Rack	15minutes
Two Racks	30 minutes

## Prerequisites

- Review these instructions before beginning.
- All wiring must comply with the National Electric Code (NEC) and local regulations.

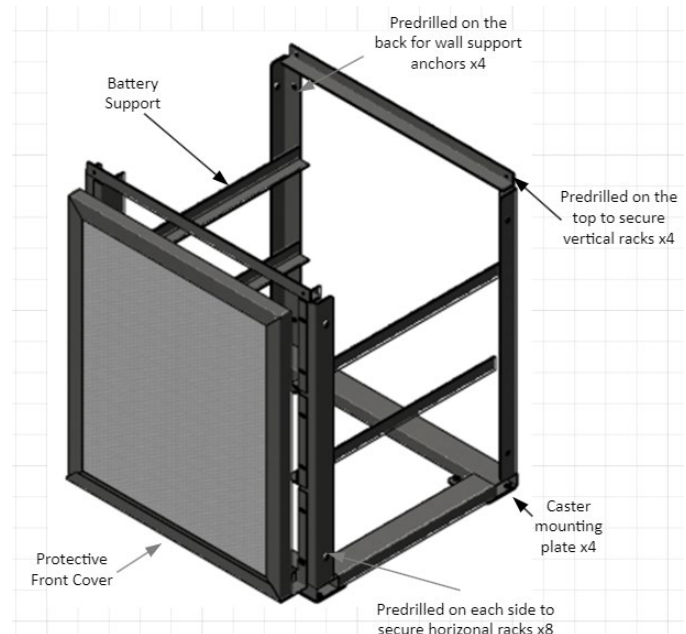

Information in this document is based on specifications believed correct at the time of publication. The right is reserved to make changes as design improvements are introduced. PowerUpESS is a registered trademark of PowerUpESS LLC. Other product or company names mentioned herein may be the trademarks of their respective owners. © PowerUpESS LLC

## Accessories

Part Number	Description
BRCAS300	4 casters

## Installation

Select a location:

- Select a flat location with a structure strong enough to hold 700lb.
- If you are stacking two racks, the back should be supported by a wall structure able to prevent tipping.
- Select a dry location free of flammable material.

Install optional casters.

- Flip rack upside down.
- Install casters with included bolts in the rethreaded locations.

Install single rack.

- Place rack directly on flat surface.
- Use appropriate wall anchor designed for the wall type and secure rack to wall.
- Install batteries starting with the lowest battery first. **WARNING:** make sure power is turned off, breaker is turned off and battery terminals are protected.
- Secure battery to rack using the 6mm screws provided with battery.
- After wiring is complete and battery turned on, install protective front cover using the integral thumb screws.

Install multiple racks.

- Racks can be configured in a horizontal and/or vertical configuration.
- Place first rack in the desired location
- Place the remaining racks vertically (maximum 2 racks) and or horizontally.
- Use 6mm x 20mm bolts with nylon lock nuts to secure all racks together.
- Use appropriate wall anchor designed for the wall type and secure each rack to wall.
- Fasten rack together using 4 holes per side
- When stacking racks use the 4 holes on top to secure top rack to the bottom rack.

Information in this document is based on specifications believed correct at the time of publication. The right is reserved to make changes as design improvements are introduced. PowerUpESS is a registered trademark of PowerUpESS LLC. Other product or company names mentioned herein may be the trademarks of their respective owners. © PowerUpESS LLC